

Rooftop & Sleeper Deck Systems

Sleeper Deck Systems

Trex® is an ideal material for applications above solid surfaces as in a rooftop deck or on top of concrete or slate provided that your installation includes a sleeper system.

A sleeper system is a buffer between the solid surface and *Trex*. Drainage, access and airflow are critical. Water must be able to flow away from the deck. Access is needed to the joist system for repairs and removal of debris when necessary. Good airflow will keep the decking dry and good-looking.

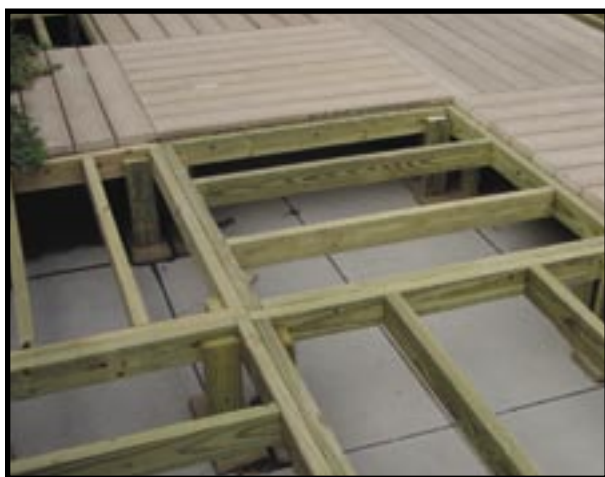

Roof-deck notes:

- Consult your building code authority for proper detail on railing installation to the roof structure.
- If access to the roof is desired, the *Trex* deck must be built in removable sections or with removable fasteners to allow access to roof.
- The sleeper joists must be attached to the roof structure in a manner that stabilizes the deck frame. Failure to do so may result in a poor structure which will compromise deck performance.

Sleeper system notes:

- Surface below the deck must be pitched for proper drainage.
- 1/4 - 1/2" gap abutting walls or other fixed objects.
- Gaps between deck boards shall be 3/8" minimum on a sleeper system.
- Minimum height of a sleeper joist is 3-1/2".
- *Trex*, when used with a sleeper system, must be supported below its entire length and run the direction of the pitch of the roof to facilitate proper drainage.

Bridging the Gap

Marine decking (HS24)

The marine industry brings out the best in a great building product. Standing up to the constant exposure to sun, moisture, and salt is a challenge for any building product. Trex Company has met the challenge with HS24 - a product that can stand up to nature while providing an attractive, splinter-free, slip-resistant surface for bare feet.

When your plans call for 24" spans, use HS24 2x6. These 2x6's are the most rigid deck boards Trex® offer. They are stocked in two distinct colors: Natural and Winchester Grey. These colors were chosen for their exceptional beauty in waterfront settings. HS24 2x6 is clearly identified by the unique "HS24" code stamped on the side of the board.

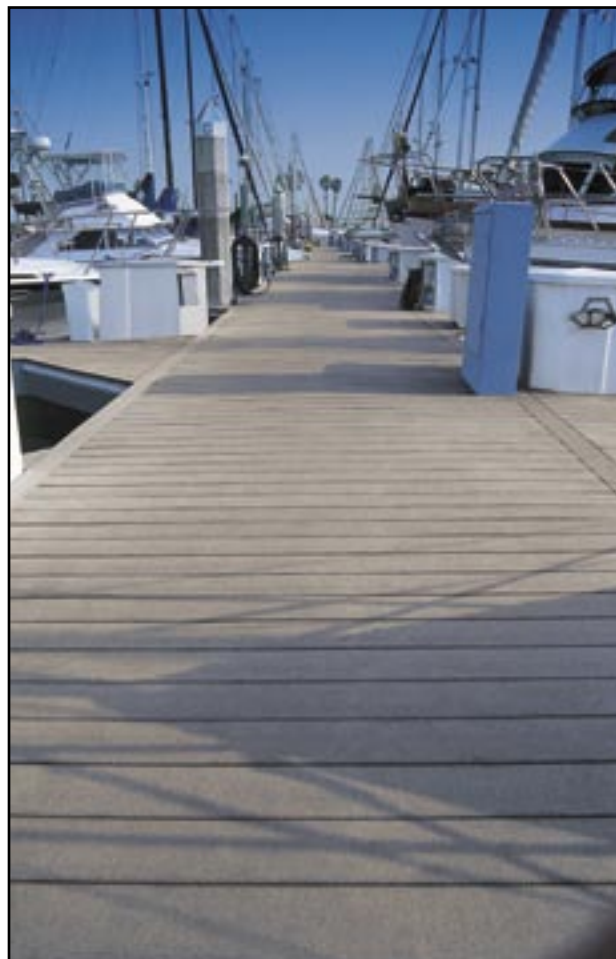

Outside the Box

Special Designs

Trex® decking and railing lets you create a deck unlike any other. Our innovative products allow limitless opportunities to express your individual creativity.

- Multi-Tone Design Capability
- Curved Decking
- Sunburst
- Traditional Curved Railings
- Curved Stairs



Madeira and Natural



Madeira

Don't Be Square

Bending Detail

Suggested methods for bending Trex®:

Trex boards can be bent without being heated when the outside temperature is above 80°F. Trex 5/4 x 6 or 2 x 4 boards, laying flat, can be bent to achieve a 20 foot radius when formed as in Illustration #1.

To assist in the bending of Trex, you can use a non-flammable pipe/tube and a portable heater with fan to heat boards to approximately 140°F internal temperature. See Illustration #2. To achieve this temperature, heat boards a minimum of 30-45 minutes. To minimize damage to the board surface near the heater, flip boards after 20 minutes or move heater to other end of the tube.

Joist spans must be reduced to 12 inches to accommodate Trex installed in curved configurations.

Illustration #1

Suggested Methods for Bending Trex (without heating) for Decking at an ambient temperature of 80 °F or higher

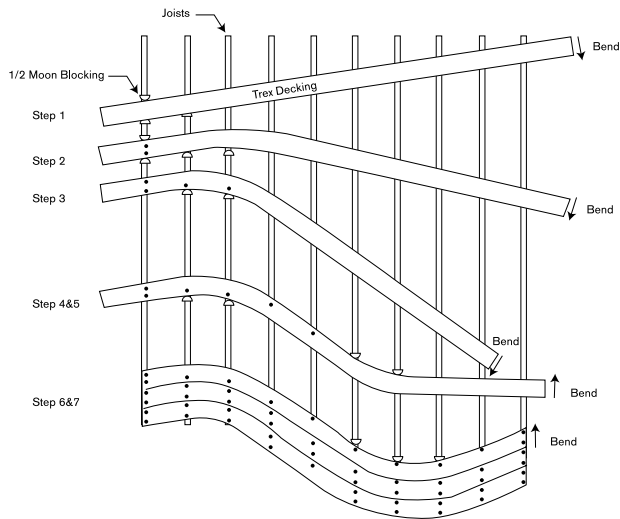
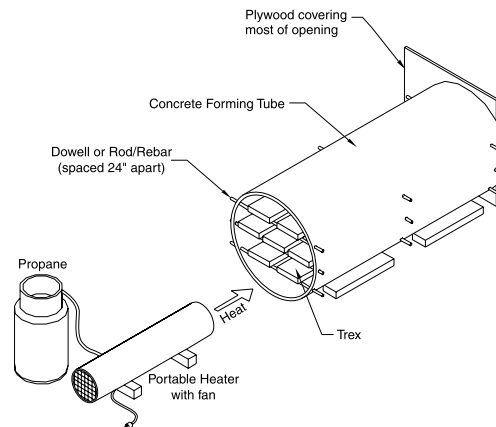

Illustration #2

Non-Flammable Tube or Pipe & Portable Heater System



Don't Be Square

Bending Tips

- 1) Installing curved profiles will take considerably more time than installing straight profiles.
- 2) Heaters larger than 100,000BTU will require less time to heat *Trex* profiles.
- 3) Bending boards in this manner places them under considerable stress. Boards may break. The most common causes are:
 - a. The boards are not hot enough
 - b. Bending is being done at a rate faster than 1" per second
- 4) Railings need to be bent as in either Option #1, #2 or #3 as shown on the following page.
- 5) Attach fasteners only on inside of curve, until boards are bent entirely into place. Then fill in rest of the fasteners.

Illustration #1

Bending Trex® Decking



Illustration #2

Bending Trex Designer Series Railing™



Bending Radius	Method	Heating Time	Difficulty Level
20'+	Lay on Hot Asphalt	1 hour	Intermediate
20'+	Tube & Heater	30 min.	Beginner
15-20'	Tube & Heater	45 min.	Intermediate
8-15'	Tube & Heater	45+ min.	Expert
4-10'+	Rip into strips (Option 2)	0-15 min.	Expert
Designer Railing 15'+	Tube/Heater & Strips (Option #2 or #3)	45+ min.	Expert

Note: Increase bending radius by 2 feet when using 2 x 6 profiles.

Curved Rail

Suggested Method for Bending Trex® for Top Plate & Tips

Note:

Railings are challenging to bend. Allow for extra time and materials. Use one of the methods shown below.

Option 3:

Heat Trex as in Illustration #2, and use a jig to layout desired curve similar to Illustration #3. Bend the boards or rail into the arc and secure in place. Allow deck boards to cool at least 3-4 hours, and rails for at least 6 hours. After cooling, take out the profile and install on deck or rail surface.

Illustration #3

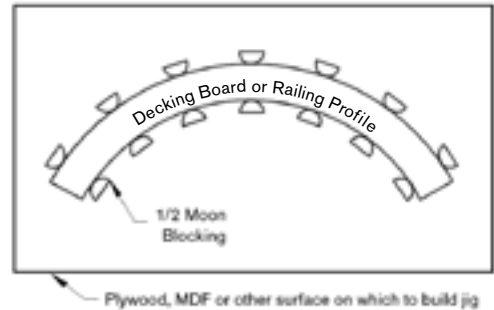

Option 1:

Cut from Trex in appropriate widths to form curved top plate.

Option 2:

Ripped from Trex into narrower widths, bent in place and re-fastened into desired width top plate.

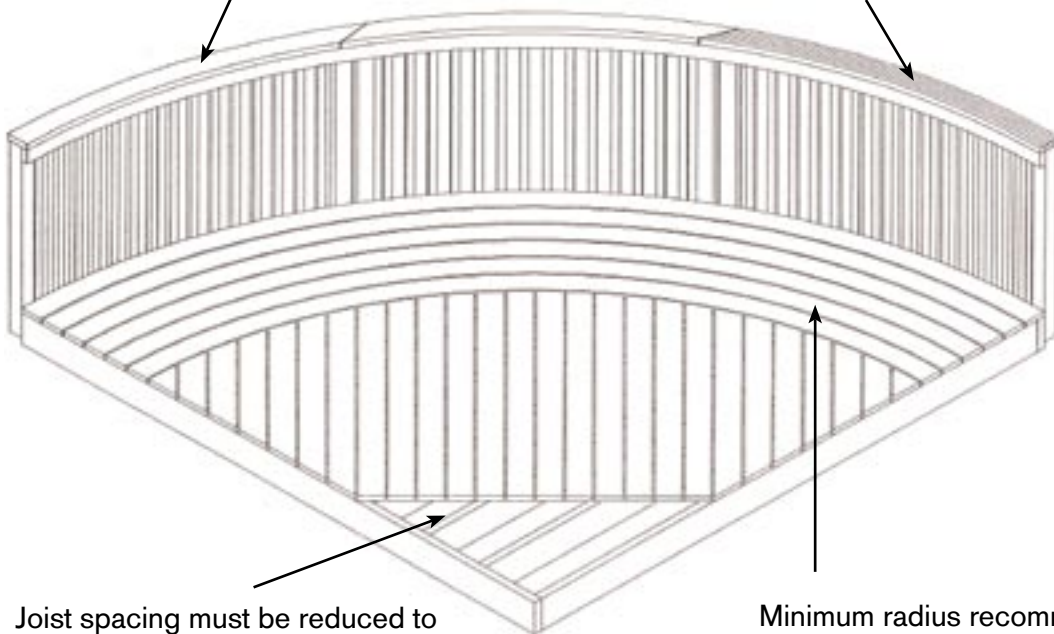

Joist spacing must be reduced to accommodate Trex installed at a 45° angle (see page 14).

Minimum radius recommended for bending decking is 8 feet (see page 29).

Note: Trex Designer Series Railings™ are more difficult to bend than standard decking profiles.

Let the Sun Shine

Sunburst Assembly Detail

To install a 180°, 8' radius sunburst using Trex® 2 x 6 or 5/4 x 6 boards, lay out the 58 boards before fastening to ensure proper and consistent gapping.

Trex Tip:

- Please follow local building codes in framing a sunburst.
- Remember to gap all decking boards according to the guidelines on page 15.
- The minimum recommended width of the tip, closest to the inside of the sunburst is 1/2".

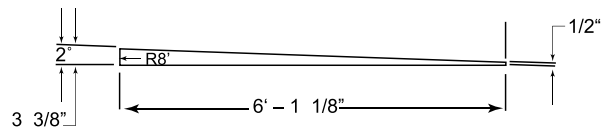
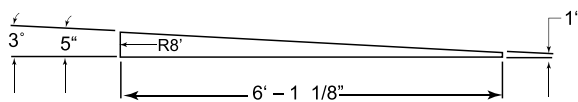
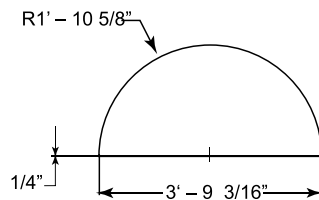
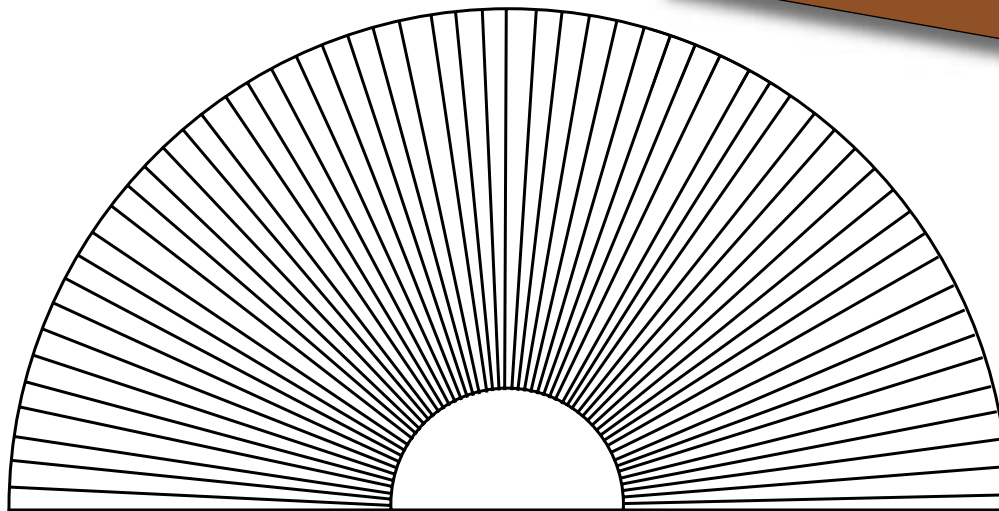

For completing a 180° sunburst, you will need to cut 56 Trex 2 x 6 or 5/4 x 6 boards to the dimensions in the illustration above. Please add 1" to the length of the board to allow for routing the outside of the sunburst. Each board should represent a 3° angle.

To finish the sunburst, you will need to cut 2 boards to the dimension in the illustration above and install them on each end of the half-circle. Please add 1" to the length of the board to allow for routing. Each board should represent a 2° angle.

Multiple Uses

Amenities

Trex® is not just decking and railing. You can use our products for numerous other outdoor applications, creating a durable outdoor environment that will provide enjoyment for years to come. Trex is

not a structural member. Wood supports are recommended. Please consult with your local building authority.



Benches and Seats



Planters and Skirting



Edging



Playgrounds

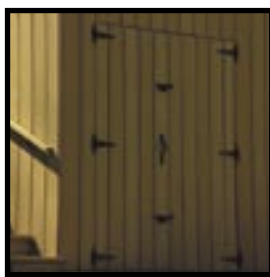

Storage Shed Siding

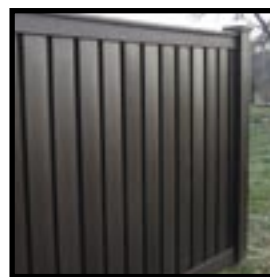

Fencing